

Product

DATA

Data sheet no DS0403340 EN
2011 • version 3.1

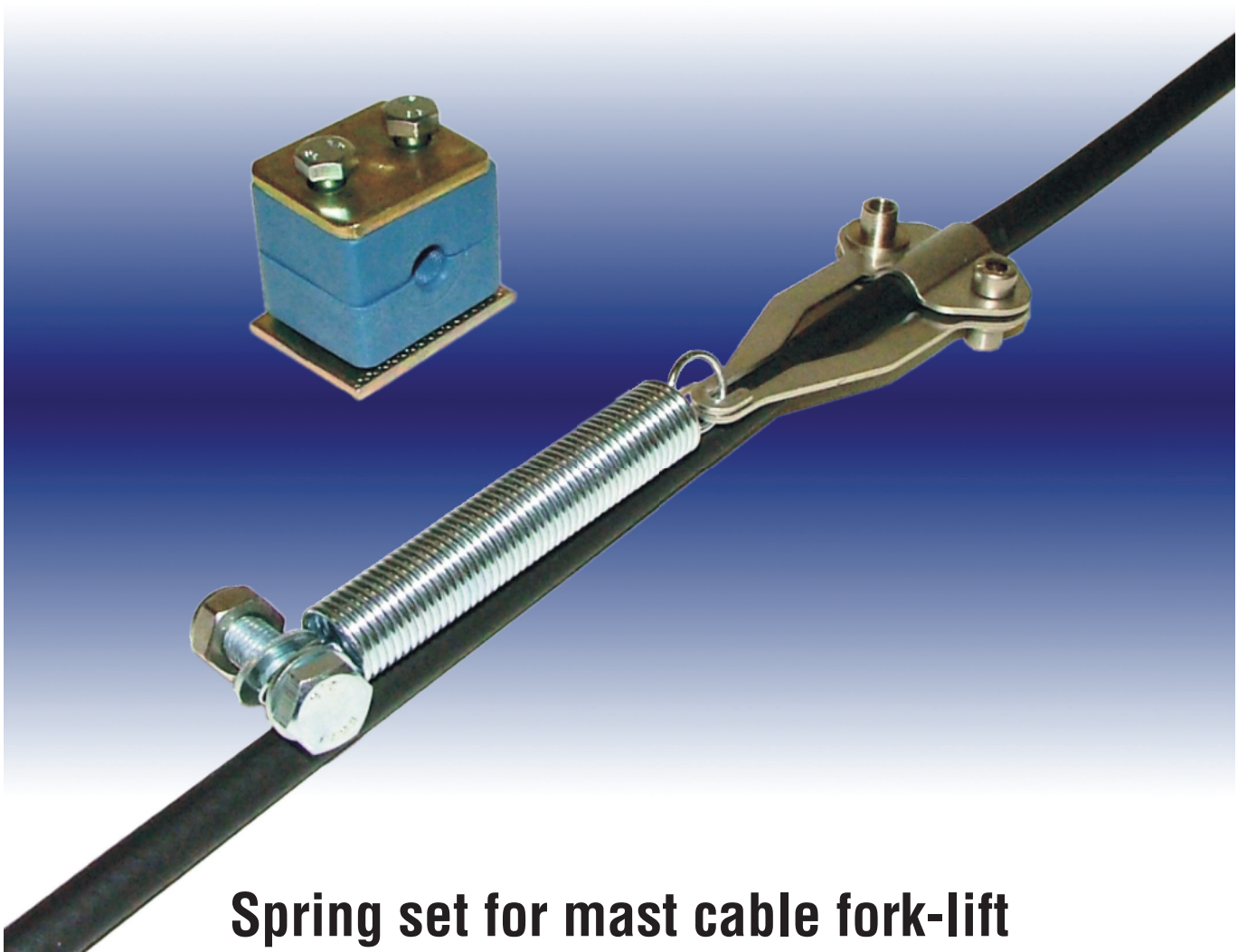

Spring set for mast cable fork-lift



Article no 0403340

luginbühl
fahrzeug- und werkstatttechnik

Bruneggerstrasse 45, 5103 Möriken
Telefon 062-893 24 24, info@luginbuehl-ag.ch, www.luginbuehl-ag.ch



Technical Specifications

Spring set for mast cable fork-lift

Article number	0403340
Application	Suitable for Orloco Mast cables: range \varnothing 8,5 mm - 9,6 mm.
Operating temp.	-40°C to +85°C.
Weight	0,178 kg.
Included	Mounting material and extra cable holder (2 pcs.)

Installation

Standard fork-lift

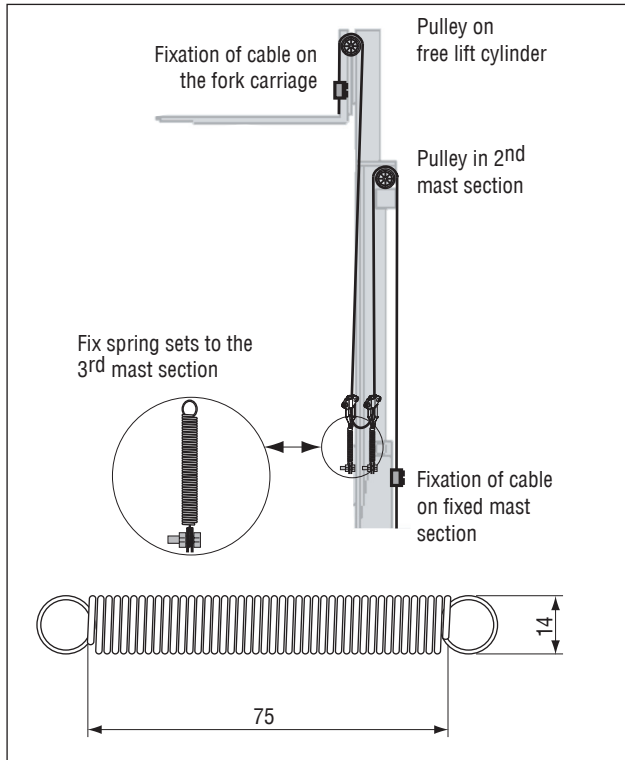

Linde R 115 fork-lift

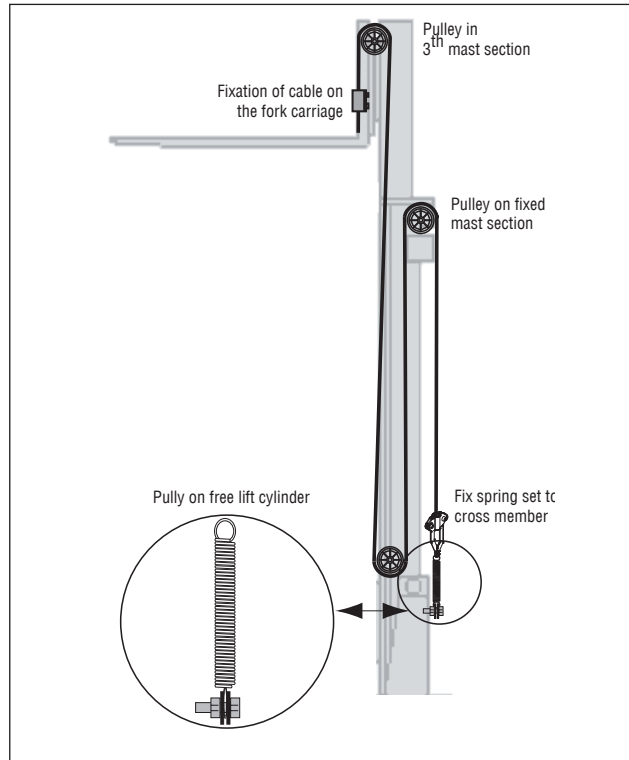

Dimensions

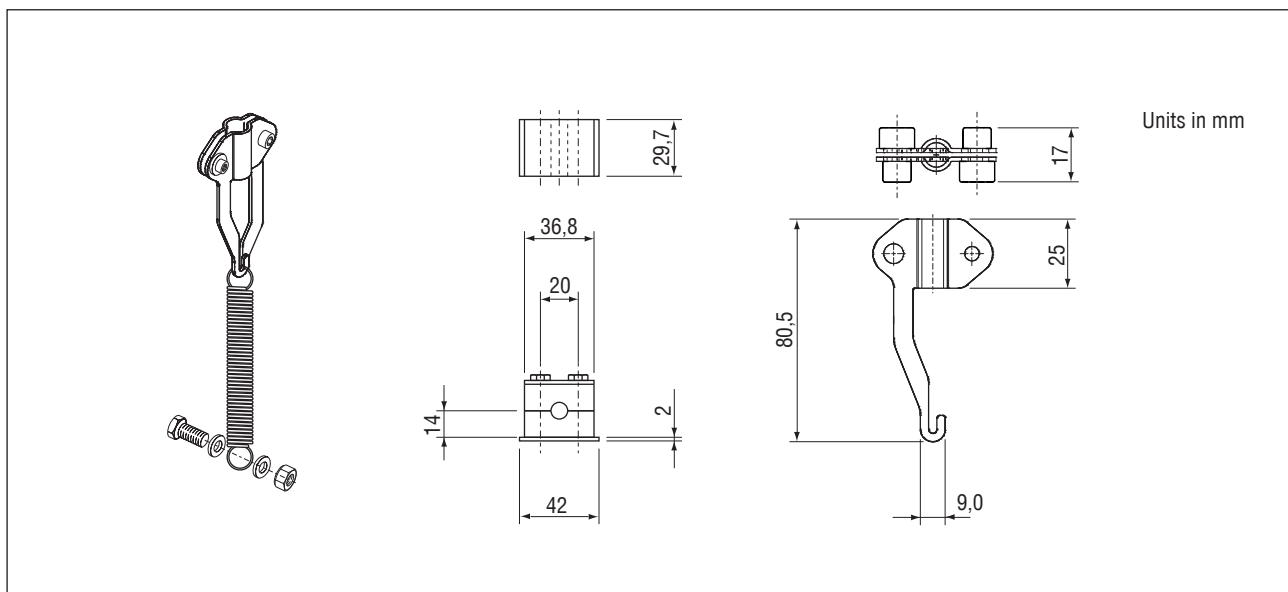

All data subject to change without notice. All dimensions are for commercial purpose only.
 The camera/display systems from Orloco comply with the latest CE, ADR, EMC and mirror-directive regulations.
 All products are manufactured in accordance with the ISO 9001 quality management system, ISO 14001 environmental management systems and all Ex products with the IECEx scheme and ATEX directives.



luginbühl
 fahrzeug- und werkstatttechnik